



onivo.ca

COUNTER 3D

SETUP INSTRUCTION



TRANSPORTABLE

2 wheels for easy transport!

1. Setup the COUNTER 3D to align all parts (2 tables and base).
2. Empty the base compartments to not make the COUNTER 3D too heavy.
3. Lift up the COUNTER 3D gently by the upper table.
4. Push gently.

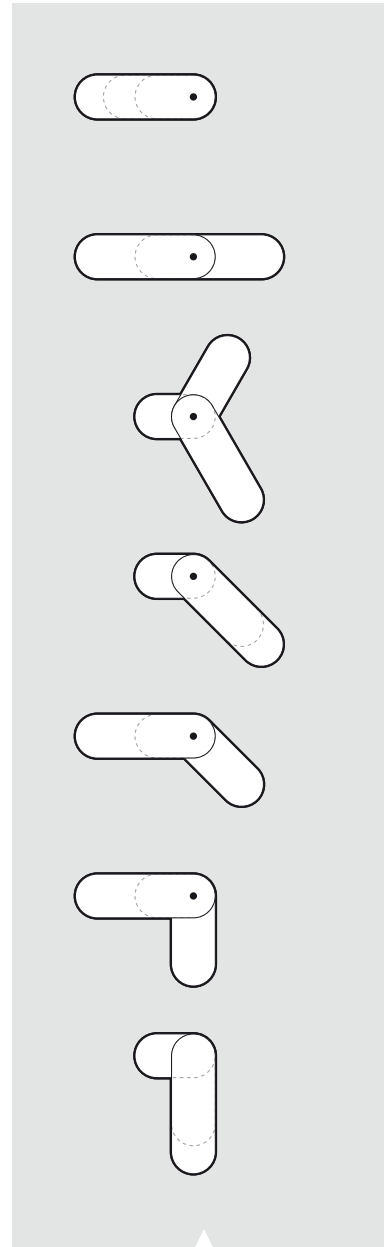

Examples for set-up options

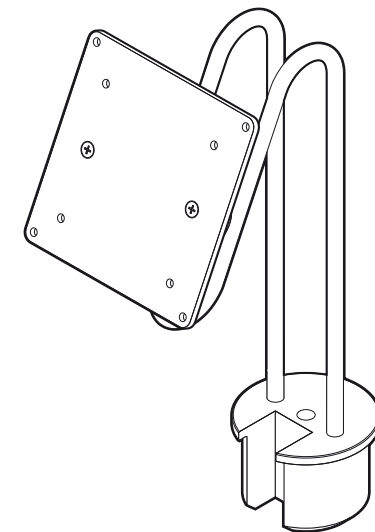
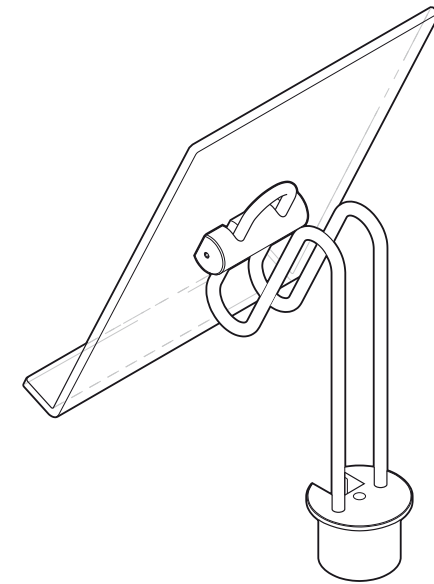

Optional parts

PARTS OF 3D COUNTER

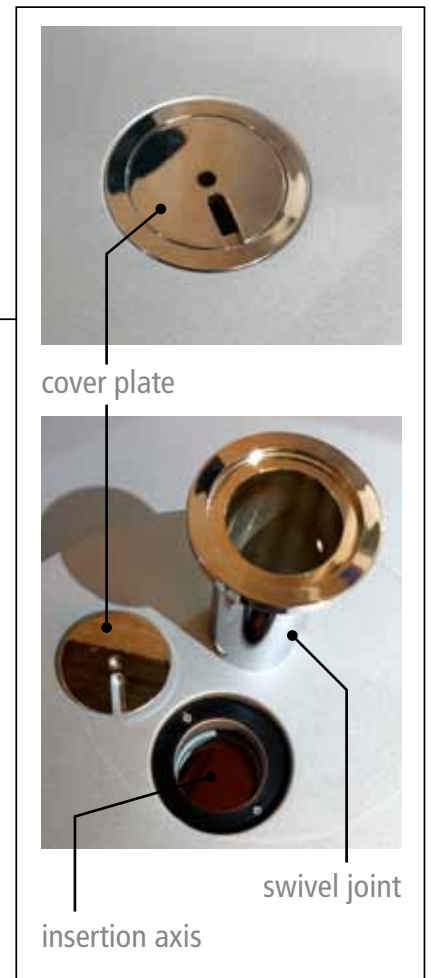
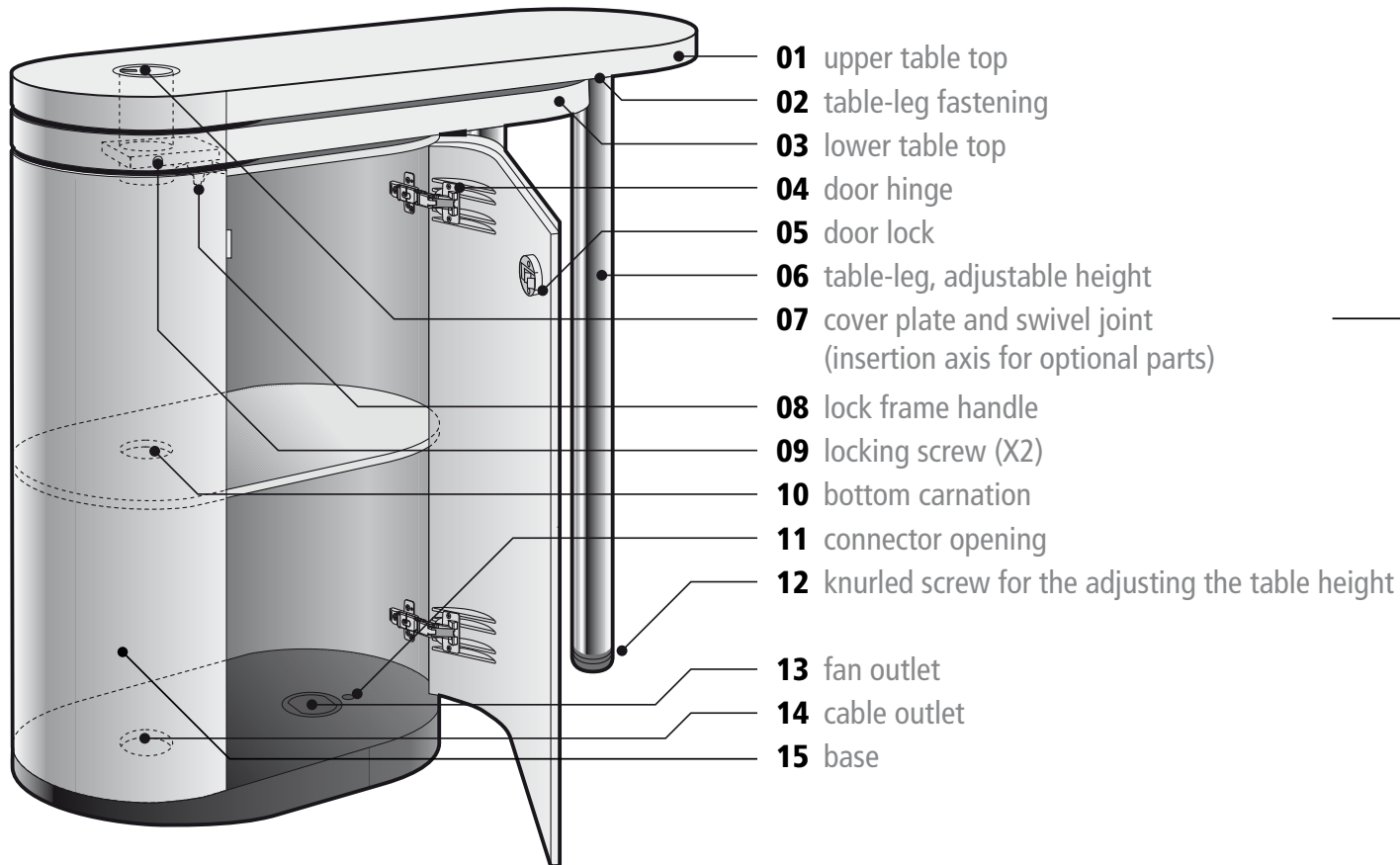

WARNING!

To take out the COUNTER 3D of the box without damage, you MUST take it by inside. So first and foremost, open the door of COUNTER 3D.



Pull gently the COUNTER 3D out of the box.



Setup the COUNTER 3D begin by removing cover plate and swivel joint from insertion axis **(07)**.



Remove the elastic tying the cover plate **(07)** and the lock frame handle **(08)** by passing inside the swivel joint. The elastic is used to fix these parts during transport in the box.



Loosen the handle of the lock frame handle **(08)**.



Pull the two locking screws **(09)** to release access to the swivel joint **(07)**.



Push the swivel joint **(07)** upwards to extract it from the insertion axis.

Store the cover plate and swivel joint on the first shelf inside the COUNTER 3D.



Take the lower table top **(03)** and place it upside down on the top of the base **(15)**.



Take the shortest table-leg **(06)** and screw it firmly under the lower table top.



Flip the lower table top with its leg on the base aligning the insertion axis.



Take the upper table top **(01)** and place it upside down on the top of lower table top **(03)**.



Take the long table-leg **(06)** and screw it firmly under the upper table top.



Flip the upper table top with its leg on the lower table top aligning the insertion axis.

Insert the swivel joint into the insertion axis through both tables and the top of the COUNTER 3D, and replace the cover plate.



When done, place the two table tops at the desired position.



Close the lock frame.



Engage the two locking screws and tighten the lock frame handle **(08)**.



Adjust the height of the tables using knurled screws **(12)** under the table legs.

That's it!

